

Standard Preparation 1600 mm Vegetables Processing/ Washing Table with Upstand

ITEM # _____

MODEL # _____

NAME # _____

SIS # _____

AIA # _____

132766 (TLV1600PN)

Vegetables Processing Table with 2 polythene cutting boards, knife holder, 2 perforated Top covers and upstand, 1600mm

Short Form Specification

Item No. _____

50mm high worktop in 304 AISI stainless steel , 2 bowls (684x303x180h mm). Integral radiused rear upstand, h=100mm. Square section legs 40x40mm on 1" height-adjustable feet in 304 AISI stainless steel.

N.1 polythene cutting board and scraping hole on front.

Main Features

- Sturdiness, stability and reliability of table accurately tested.

Construction

- Table can be equipped with a mobile bin with lid for waste disposal (optional accessory).
- 50 mm worktop in 304 AISI stainless steel, 10/10 in thickness with upturned edges and reinforced waterproof underpanel, incorporates a layer of sound deadening materials.
- Square section legs and 40 mm height-adjustable feet in 304 AISI stainless steel.
- Table can be equipped with a set of castors as an alternative to the feet.
- 100 mm upstand with 10 mm radiused corner and 13 mm deep, designed to be used against a wall.
- Upstand back completely covered with Stainless Steel welded profile.

Optional Accessories

- Lower shelf for 1600mm tables and sinks PNC 855147
- Set of 4 wheels (2 with brake) d. 100mm for tables and sinks (total height on wheels= 993 mm) PNC 855150
- 3-sided underframe for 1600mm tables PNC 855154
- Single plastic drain syphon 1,5 " for work tables with bowl PNC 855306
- Elbow operated mixer tap with spout 3/4", single hole PNC 855322
- Elbow operated mixer tap with short spout 3/4", single hole PNC 855323
- Foot operated mixer tap (hot and cold) with spout 3/4" PNC 855328

APPROVAL: _____

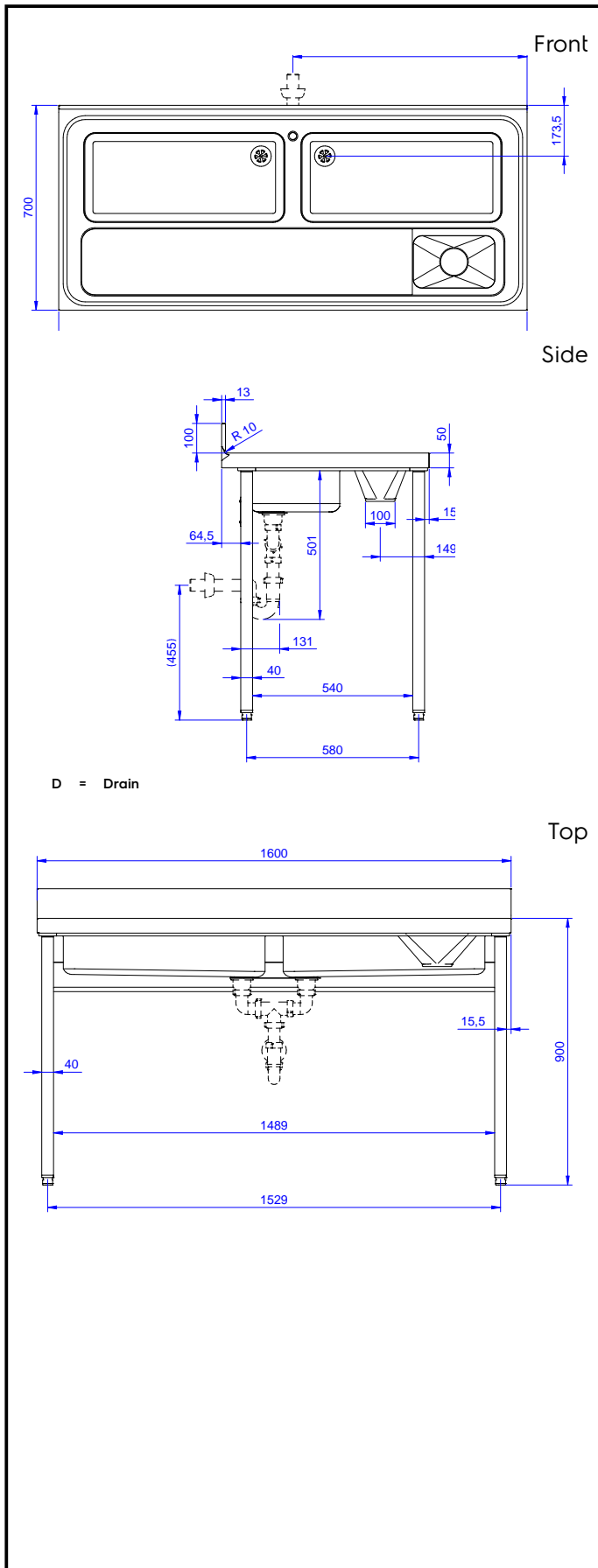

Key Information:

External dimensions, Width:	132766 (TLV1600PN)	1600 mm
External dimensions, Depth:		700 mm
External dimensions, Height:		1000 mm
Upstand Dimensions, Height:		100 mm
Upstand Dimensions, Depth:		13 mm
Upstand Dimensions, Radius:		R=10
Worktop thickness:		50 mm
Net weight:		60 kg
Number of cutting boards		2
Cutting board dimensions - width		430 mm
Cutting board dimensions - depth		640 mm
Cutting board dimensions - height		25 mm